

Top View

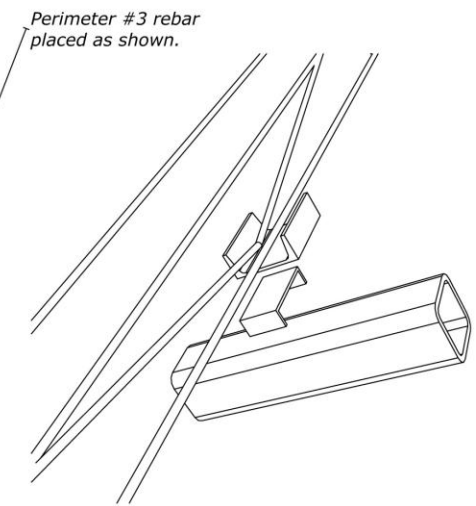

Steel Bracket Detail

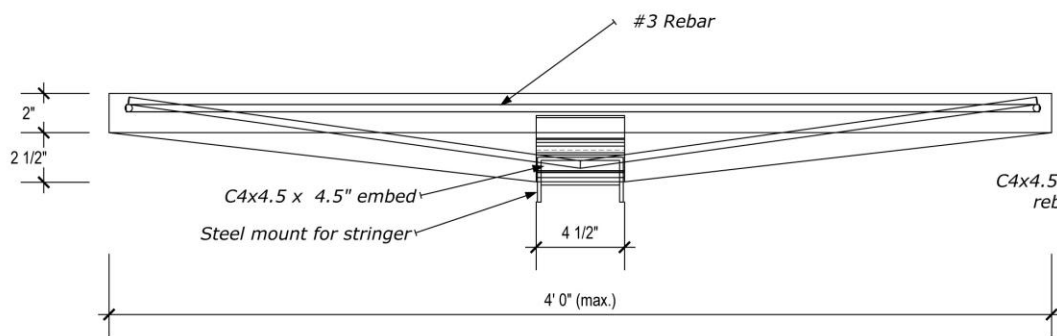

Front View

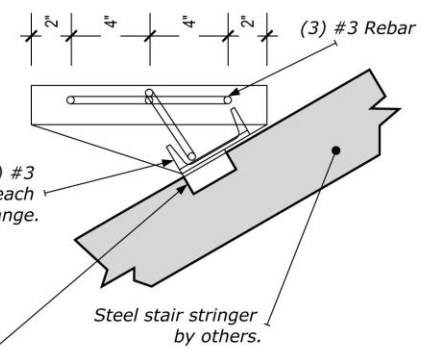

Section View

Plate 3/16" x 1" x 4" field welded to both embed & stair stringer with 1/4 fillet weld.